



The B-Class

Price List from 1st July to 31st August 2024

Mercedes-Benz



Welcome

At Mercedes-Benz we appreciate the importance of detail. Over the following pages you'll find model prices and a breakdown of standard and optional equipment, as well as details of the attractive finance offers and benefits that are available to every Mercedes-Benz driver.

We have highlighted some of the best styling features both inside and out, some of the new technology features and some body styling options which all combine to give you a unique driving experience. To experience a full listing of what is available; please speak directly to your local Mercedes-Benz Dealer.

Of course, some things have to be experienced to be truly appreciated, such as the qualities that set a Mercedes-Benz apart, which is why we'd like to invite you for a test drive at your local Mercedes-Benz Dealership. Discover the location and the contact details of your local Mercedes-Benz Dealership at www.mercedes-benz.ie

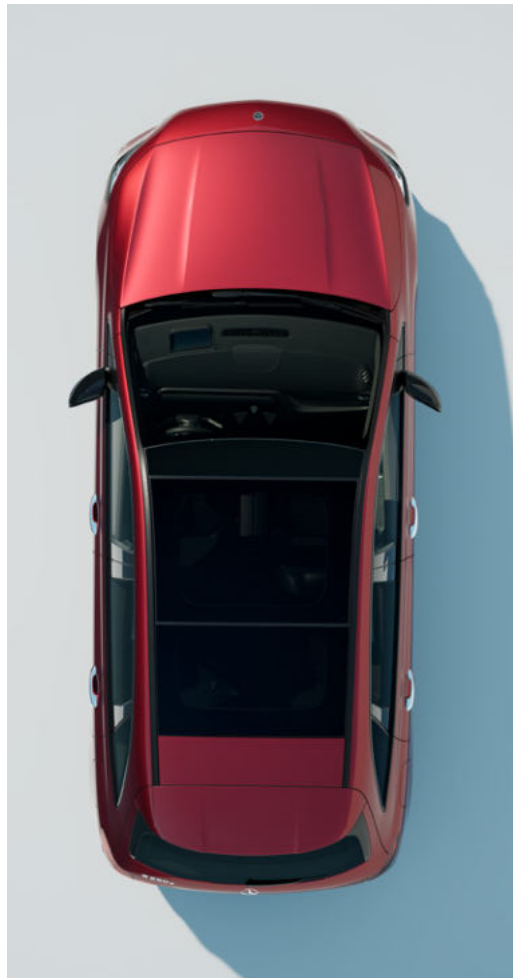

Some of the model features, optional extras and colours shown may not be available, or may only be available in a different specification, or at a different price.

Price List

Petrol

Model Description	Wheel size	CO2	VRT Rate	Road Tax	CC	BHP	Price*
B 180 Progressive	17"	136-140	20.00%	€210	1332	136	€51,030
B 180 AMG Line	18"	141-145	21.50%	€270	1332	136	€55,718
B 200 Progressive	17"	136-140	20.00%	€210	1332	163	€53,015
B 200 AMG Line	18"	141-145	21.50%	€270	1332	163	€57,738

Petrol Plug in Hybrid

Model Description	Wheel size	CO2	VRT Rate	Road Tax	CC	BHP	Price*
B 250 e Progressive Plus	17"	0-50	7.00%	€140	1332	**	€61,395
B 250 e AMG Line Plus	18"	0-50	7.00%	€140	1332	**	€64,665

** 1,332cc, 4-cylinder, 160hp - Electric Motor 102hp. System Output 218hp.

Diesel

Model Description	Wheel size	CO2	VRT Rate	Road Tax	CC	BHP	Price*
B 180 d Progressive	17"	136-140	20.00%	€210	1950	116	€52,855
B 180 d AMG Line	18"	136-140	20.00%	€210	1950	116	€56,604
B 200 d Progressive	17"	131-135	19.25%	€210	1950	150	€54,895
B 200 d AMG Line	18"	136-140	20.00%	€210	1950	150	€59,104

* Prices applicable to all models registered from 1st July to 31st August 2024. Subject to availability. Terms & Conditions apply. Prices quoted do not include dealer and delivery related charges.

Owing to supply shortages, options for vehicles may be temporarily restricted, resulting in modified vehicle and/or package pricing. Regularly updated information on this issue is available from Mercedes-Benz dealers.



B-Class

Technology

Some of the model features, optional extras and colours shown may not be available, or may only be available in a different specification, or at a different price.

Mercedes-Benz User Experience (MBUX)

Transforming the in-car user experience, thanks to MBUX: Controlled via voice or touch input, the innovative infotainment system can over time even predict personal habits thanks to artificial intelligence.

Voice control

- Activated by the keywords “Hey Mercedes”, the new intelligent voice control LINGUATRONIC¹ lets you control many of the infotainment functions, including destination input, phone calls or music selection
- MBUX is able to understand different accents and will adjust to you over time
- MBUX even understands indirect commands. Feeling chilly? Just say “I feel cold” and MBUX will adjust the temperature for you

Touch inputs

- Beside voice control you can operate MBUX via touchscreen as well as touch control buttons on the steering wheel

Personalisation

- Turn the B-Class into your very own Mercedes-Benz by personalising driving modes, radio stations and much more
- Your personal settings can be saved in up to seven different profiles, making your driving experience the best one possible
- Thanks to artificial intelligence, MBUX is able to learn and adapt over time. It will be able to predict your personal habits, such as navigation for frequently-driven routes, or the radio station you like to listen to on your way home from work

Maintenance and service

- Wondering when the next service is due? Or how much further you can drive until you need to stop at a petrol station? Just ask your MBUX – it will tell you the answer



¹LINGUATRONIC off-board functions are currently only available for three years

Mercedes me connect

Stay connected any time, anywhere.

Mercedes me

Mercedes me is a range of innovative online services designed to enhance your Mercedes-Benz experience. Accessible via mobile, tablet or PC, Mercedes me lets you enjoy the highest standards of care and support, in a way that integrates seamlessly with your busy lifestyle.

Safety and Service – Mercedes me connect helps to keep you and your car safe

Check your car's washer fluid level, tyre pressure and battery level from your phone so you'll be ready for every journey.

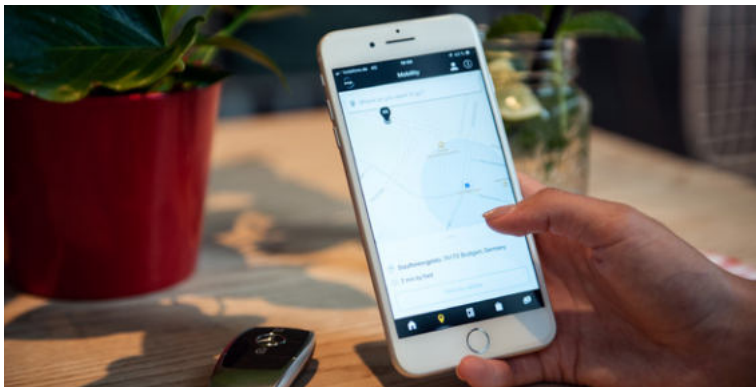

Live Traffic Information, Parked Vehicle Locator and much more with Mercedes me connect

Forgot where you've parked? Parked Vehicle Locator¹ will show you exactly where your car is as long as you're in a 1.5 km radius of where you parked. Real-time traffic data and dynamic route with shorter journey times.

Comfort – connect to your car anytime, anywhere

Forgot to lock your car? With Remote Car Lock² you will receive a notification on your smartphone to let you know. With one tap, you can lock and unlock your vehicle so you never have to worry.

EQ-specific Services

Check your charging status on the go and programme your pre-entry climate control and charging settings remotely. The EQ-specific navigation considers electrical range, topography and charging stations.

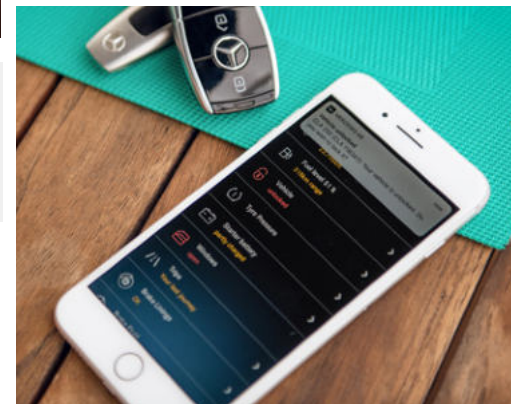

¹Available on all models with the Vehicle Monitoring package. This option may vary between standard and additional cost dependent on the model

²Part of the Vehicle Status package. This option may vary between standard and additional cost dependent on the model

Images shown are for illustration purposes only

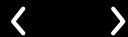

B-Class

Plug-in Hybrid

Plug-in Hybrid Electric Vehicle (PHEV) The B 250 e.

Plug-in hybrid vehicles enjoy the same functionality of full Hybrid technology, with the added benefit that they can be charged from an external electricity source. With CO₂ emissions of 23 g/km or less, the B 250 e Plug-in Hybrid is an environmentally conscious choice of driving.

B 250 e:
Petrol – 1,332 cc, 4-cylinder, 160 hp/120 kW Electric motor – 102hp/80kW



Standard equipment

AC charging system rated at 11 kW AC

Acoustic ambient protection – the tone pitch changes depending on the driving conditions. You can therefore also differentiate whether you are braking or accelerating. Above 30 km/h, the system is basically deactivated since wind and tyre noise tend to dominate at higher speeds

Advanced Plus Package featuring... All Digital Instrument Cluster, Ambient Lighting, KEYLESS GO Comfort Package & Wireless Phone Charging*.

Charging cable – Mode 3 cable (5 metres, straight) for wallbox and public charging stations

Charging socket

Comfort suspension

Pre-entry climate control

Radar-based recuperation

Remote and Charging Services Plus

*Compatible mobile phone required

Technical details

Equivalent All-Electric Range (EAER) ²	74–75 km
Charging time	
AC charging station (11 kW AC) 10–100% ³	1 hr 25 mins
Wallbox (11 kW AC) 10–100% ³	1 hr 45 mins
Range power consumption, combined ^{2,4}	183–213 kWh/100 km
Battery type (usable)	lithium-ion (15.6 kWh)
Capacity on-board charger	11 kW AC



²The indicated values were determined according to the prescribed measurement method – Worldwide Harmonised Light Vehicle Test Procedure (WLTP). Figures shown may include options which are not available in Ireland. For Plug-in Hybrid Electric Vehicle (PHEV) figures determined with the battery fully charged, using a combination of both battery power and fuel. These models require mains electricity for charging ³Specified voltage and current values refer to network infrastructure and can be limited by the vehicle. Times are from 10–100% charge using a wallbox (three-phase) or standard socket (single-phase) ⁴The certified electrical consumption is generally determined at maximum AC charging capacity using a Mode 3 cable. It is therefore recommended that vehicles with a HV battery preferably be charged at a wallbox or an AC charging station with a Mode 3 cable in order to achieve shorter charging times and improved charging efficiency

B-Class Model lines overview



B-Class Progressive

Standard equipment highlights



Engine, Transmission and Suspension

Driving modes - DYNAMIC SELECT with a choice of driving modes: Eco, Comfort, Sport and Individual

ECO start/stop function

Suspension - comfort suspension



Exterior

17" alloy wheels - 5-spoke design, aerodynamically optimised, painted black with a high-shine finish (code 25R)

EASY-PACK power tailgate

LED High Performance headlamps with integrated LED daytime running lights and Adaptive Highbeam Assist

Mirror package

Radiator grille with central Mercedes star and single louvre in matt grey

Summer tyres





Interior

Centre armrest – front, with stowage

Comfort seats with adjustable head restraints

Heated front seats

KEYLESS-GO starting function

Steering wheel – multifunction sports steering wheel in leather with black topstitching and bezel in silver chrome

THERMATIC automatic climate control, one-zone; automatically controlled air distribution

Velour floor mats

Communications, Safety and Assistance Systems

10.25-inch touchscreen media display

Active Brake Assist¹

MBUX multimedia system including DAB digital radio

Mercedes me Remote Services

Parking – Parking package with 180° camera

Speed Limit Assist

USB package Plus

¹Our driver assistance and safety systems are aids and do not relieve you of your responsibility as the driver. Please take note of the information in the Owner's Manual and the system limits which are described therein



Trim and Upholstery

Star pattern

ARTICO man-made leather black



B-Class AMG Line Standard equipment highlights



Option shown: MANUFAKTUR patagonia red metallic (code 993)



Option shown: MANUFAKTUR patagonia red metallic (code 993)

In addition to/replacement of Progressive:

Exterior

18" AMG alloy wheels – 5-twin-spoke design, aerodynamically optimised, painted tremolite grey with a high-sheen finish (code RQS)

AMG bodystyling – AMG front apron with front splitter, AMG side sill panels and AMG rear apron with visible exhaust tailpipe trim elements

Radiator grille with Mercedes-Benz pattern in chrome and central Mercedes star as well as single louvre in matt iridium silver with chrome inlay

Summer tyres

Comfort suspension with ride-height lowering





Interior

AMG floor mats

Pedals – brushed stainless steel sports pedals with rubber studs

Sports seats – optimise lateral support for dynamic driving and at the same time provide comfort for everyday use

Steering wheel – 3-spoke multifunction sports steering wheel in nappa leather with flattened bottom section and perforated grip area

Trim and Upholstery

Carbon-structure trim

ARTICO man-made leather/MICROCUT microfibre
black with contrasting stitching in red

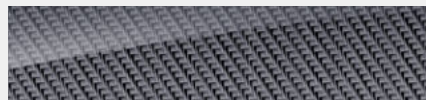

Progressive Upholstery



ARTICO man-made leather black (101A) Standard



ARTICO man-made leather macchiato beige / black (105A) Option



ARTICO man-made leather sage grey / black(158A) Option¹



Leather black (211A) Option²

1. Requires Sports Seats (7U3)
2. Requires Sports Seats (7U3) + Leather Package (P34)

AMG Line Upholstery



ARTICO man-made leather upholstery / MICROCUT microfibre black (65 1A) Standard



ARTICO man-made leather sage grey / black (158A) Option



ARTICO man-made leather upholstery / MICROCUT microfibre Bahia brown / black (654A) Option



Two-tone leather red pepper / black (277A) Option¹

1. Requires AMG Leather Package (P39)

Progressive Trim



Star Pattern trim elements (55H) Standard



Black open-pore linden wood trim (H15) Option



Brown open-pore lime wood trim (03H) Option



Light longitudinal-grain aluminium trim (H44) Option

AMG Line Trim



Carbon-structure trim (H62) Standard



Black open-pore linden wood trim (H15) Option



Light longitudinal-grain aluminium trim (H44) Option

Equipment Packages



Special equipment <small>Sometimes equipment will be replaced by an upgrade.</small>	Advanced Package <small>always included</small>	Advanced Plus Package <small>from* €1,592</small>	Premium Package <small>from* €4,191</small>	Premium Plus Package <small>€8,967</small>
Parking package with reversing camera	✓	✓	✓	×
Parking Package with 360-degree camera	×	×	×	✓
4-way lumbar support	✓	✓	✓	✓
Mirror Package	✓	✓	✓	✓
Adaptive Highbeam Assist	✓	×	×	×
Blind Spot Assist	×	×	✓	✓
Adaptive Highbeam Assist Plus	×	×	×	✓
EASY-PACK tailgate	✓	✓	✓	✓
Wireless charging system for mobile devices in the front	×	✓	✓	✓
Ambient lighting	×	✓	✓	✓
All-digital instrument display	×	✓	✓	✓
KEYLESS-GO Comfort Package	×	✓	✓	✓
MBUX Navigation Premium	×	×	✓	✓
Door sills with "Mercedes-Benz" lettering, illuminated and with exchangeable cover	×	×	✓	✓
THERMOTRONIC automatic climate control	×	×	✓	✓
Advanced Sound System	×	×	✓	✓
MBUX Interior Assistant	×	×	×	✓
Head-up display	×	×	×	✓
Surround lighting with projection of brand logo	×	×	×	✓
Driver's seat, electrically adjustable with memory function	×	×	×	✓
Power front left seat with memory function	×	×	×	✓
Panoramic sliding sunroof	×	×	×	✓

*Price and availability subject to vehicle specification and VRT rate.

Owing to supply shortages, options for vehicles may be temporarily restricted, resulting in modified vehicle and/or package pricing. Regularly updated information on this issue is available from Mercedes-Benz dealers.

Night Package

From¹ €643

With the Night package, you can set visual highlights and show your sense of expressive design and individuality. The trim elements on the front and rear aprons, as well as the single louvre on the radiator grille, are in high-gloss black for example.

- Central Mercedes star and single radiator grille louvre in high-gloss black with chrome insert
- Exterior mirror housings painted in solid paint finish night black (696U), in combination with metallic paint cosmos black (191U) painted in body colour
- Beltline and windowline trim strip in high-gloss black
- Heat-insulating dark-tinted glass from B-pillar

for Progressive (P59):

- Front apron with trim element in high-gloss black
- Rear apron with trim element in high-gloss black

for AMG Line (950):

- AMG front apron with front splitter in high-gloss black
- AMG rear apron with trim element in high-gloss black
- 18-inch AMG 5-twin-spoke light-alloy wheels (RQT), aerodynamically optimised and painted in black with a high-sheen finish



Colour options

Non-metallic, metallic and MANUFAKTUR paints



696 night black non-metallic

Standard



970 spectral blue metallic

Option



787 mountain grey metallic

Option



993 MANUFAKTUR patagonia red metallic

Option



149 polar white non-metallic

No cost option



191 cosmos black metallic

Option



922 high-tech silver metallic

Option



662 MANUFAKTUR mountain grey magno'

Option

Technical data

Model		B 200	B 220 d
Engine			
Fuel delivery		Petrol	Diesel
Total displacement	cc	1,332	1,950
Arrangement/cylinders/valves		in-line/4/16	in-line/4/16
Power ¹	hp (kW) at rpm		
Combustion engine		163 (120)/5,500	150 (110)/3,400-
Mild hybrid drive		14 (10)	4,400 -
Torque ¹	Nm at rpm		
Combustion engine		270/2,000-3,500	320/1,400-3,200
Compression ratio		11.8:1	15.5:1
Emissions standard		EURO 6D-ISC-FCM	EURO 6D-ISC-FCM
Transmission			
7G-DCT 7-speed automatic		●	-
8G-DCT 8-speed automatic		-	●
Performance			
Acceleration 0-62 km/h	sec	8.4	8.5
Top speed	km/h	223	234

Model		B 200	B 220 d
Weights and capacities			
Kerb weight ²	kg	1,490	1,580
Perm. Gross Vehicle Weight	kg	2,000	2,090
Boot capacity - seats up		420	445
seats down	l	1,505	1,530
Towing capacity - unbraked		745	750
braked	kg	1,600	1,600
Fuel tank capacity/of which reserve	l	43/5	43/5
Turning circle	m	11.00	11.00
Fuel consumption^{3,4,5}			
Combined (consumption dependent on chosen optional equipment)	l/100 km mpg	6.5-6.1 43.5-46.3	5.5-5.1 51.4-55.4

¹Figures according to Directive 80/1269/EEC in the currently applicable version ²Mass of the vehicle in running order with at least 90% full fuel tank, plus the mass of the driver (estimated by law at 75 kg), fuel and fluids, equipped with the standard equipment as specified by the manufacturer as well as, where applicable, the mass of the body, cab, trailer coupling and spare wheel(s) as well as tools. Optional extras, additional equipment and accessories can influence the weight, residual payload, rolling resistance, aerodynamics, etc., and therefore also affect the consumption/CO₂ values ³All figures are based on a standard specification with the smallest tyre size ⁴The choice of wheels and transmission may affect CO₂ emissions and corresponding VRT rate ⁵The indicated values were determined according to the prescribed measurement method - Worldwide Harmonised Light Vehicle Test Procedure (WLTP). Figures shown may include options which are not available in Ireland.

Progressive/AMG Line

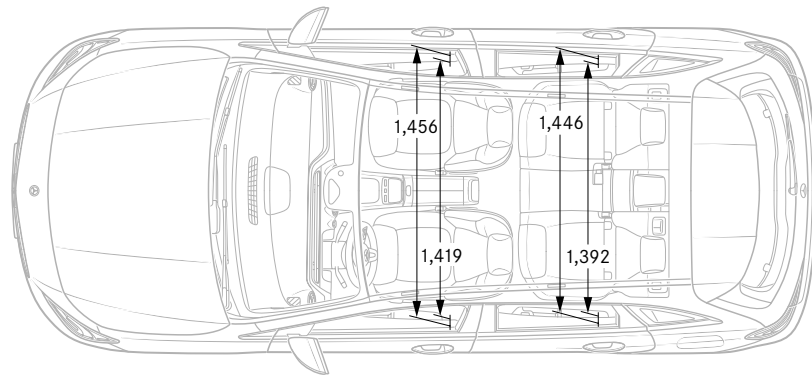
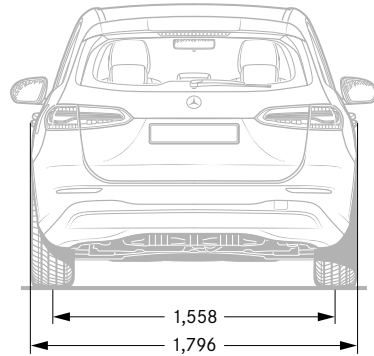
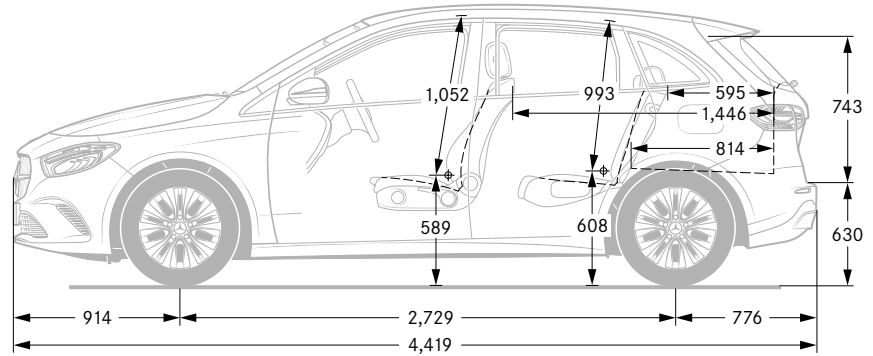
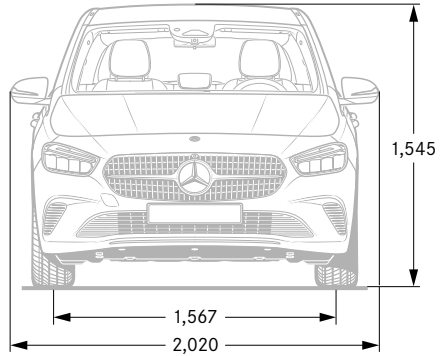

Progressive/AMG Line



Open luggage compartment behind rear seat, loaded to upper edge of rear seat backrest, volume 420 litres (V 211-2)

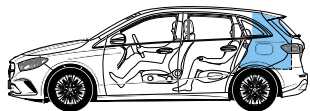

Open luggage compartment behind rear seat, loaded to roof, volume 540 litres (V 214-2)

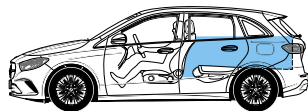

Open luggage compartment behind driver's seat, rear seat backrest folded, loaded to upper edge of driver's backrest, volume 1,065 litres (V 211-1)

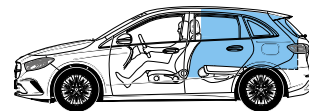

Open luggage compartment behind driver's seat, rear seat backrest folded, loaded to roof, volume 1,505 litres (V 214-1)



Largest cuboid: Dimensions 1,275 x 936 x 652 mm, volume 778 litres



Mercedes me

Welcome to your Mercedes-Benz world.

Imagine if ...you could connect with your Mercedes-Benz? With Mercedes me connect, you can! Mercedes me connect offers you new connectivity services that make driving more comfortable and incorporates your car into your personal lifestyle.

Standard Services

- Maintenance Management
- Telediagnosics
- Breakdown Management
- Accident Recovery
- Mercedes-Benz Emergency Call System

Remote Online Services¹

- Remote Retrieval of Vehicle Status (fuel level, tyre pressure etc.)
- Parked Vehicle Locator
- Vehicle Tracker
- Geofencing
- Door lock / unlock function

¹ Can be used with Remote Online special feature.





Getting connected is easy. Just set up your Mercedes me account and get in touch with your Mercedes-Benz dealer to connect your vehicle to your profile to access your Mercedes me connect services.

Contact your dealer to get connected, or go to www.mercedes.me for more details.

Follow us on the following social media channels:

 facebook.com/MercedesBenzCarsIreland

 instagram.com/mercedesbenz_cars_ireland

 linkedin.com/company/motor-distributors-ltd

 twitter.com/MercedesBenzIre

 youtube.com/mercedes-benzireland

Motor Distributors Ltd.
Naas Road
Dublin 12
Ireland
www.mercedes-benz.ie

Information correct at time of going to print. Prices and specifications are subject to change without prior notice. Prices quoted do not include dealer and delivery related charges. Images are for illustrative purposes only, actual product may vary. For more specific information in relation to the range of models, features, optional extras, colours and services available please speak to your local authorised Mercedes-Benz dealer.